

# EX-LED-M-QF QUICK FIT SURFACE LED

AESTHETIC AND FUNCTIONAL ASPECTS  
ARE MET BY THE QUICK FIT DESIGN



## TECHNICAL SPECIFICATIONS

MODEL NO:	EX-LED-M-QF
Mode of Operation:	Maintained
Lamp:	1.2W White LED module with burning life-span > 50,000 hours
Rated Duration:	3 Hours
Mains Supply:	220-240 Volts, 50-60Hz
Power Consumption:	3W (Total standby power inclusive of LED converter)
Battery:	High Temperature Nickel Cadmium
Charger:	Regulated variable rate
Charge Monitor:	LED
Test Facility:	Micro switch
Mounting:	Surface wall / Suspended / Surface ceiling
Safety Features:	Low battery voltage cut off to prevent over discharge
Diffuser:	Acrylic plate (fire retardant)
Fitting Construction:	Injection moulded with fire retardant (UL94), high impact material
Weight:	Approx. 1.2 Kg
Dimensions:	243mm (H) x 320mm (W) x 45mm (D)
Standards / Compliance:	SS IEC 60598-2-22, SS 563

## Ordering Guide:

Legend	Single Sided	Double Sided
	EX-LED-M-QF-S-RM	EX-LED-M-QF-D-RM
	EX-LED-M-QF-SR-RM	EX-LED-M-QF-DR-RM
	EX-LED-M-QF-SL-RM	EX-LED-M-QF-DL-RM
	EX-LED-M-QF-S	EX-LED-M-QF-D
	EX-LED-M-QF-SR	EX-LED-M-QF-DR
	EX-LED-M-QF-SL	EX-LED-M-QF-DL

- Designed for fast installation and easy maintenance.
- Ultra bright white LEDs meeting ISO safety colour requirements.
- Exceeds SS IEC 60598-2-22 and SS 563 brightness requirements
- Extra low power consumption
- High Quality , Long Life SMD LED module
- Numerous installations options available
- Series connection of LEDs achieve a high level of uniform light distribution and ensuring maximum life span.
- Low battery voltage cut-off with latch function , to eliminate battery over discharge.
- Durable fire retardant construction ( UL 94 ) to combat corrosion
- Lightweight ergonomics design boost productivity of installers.

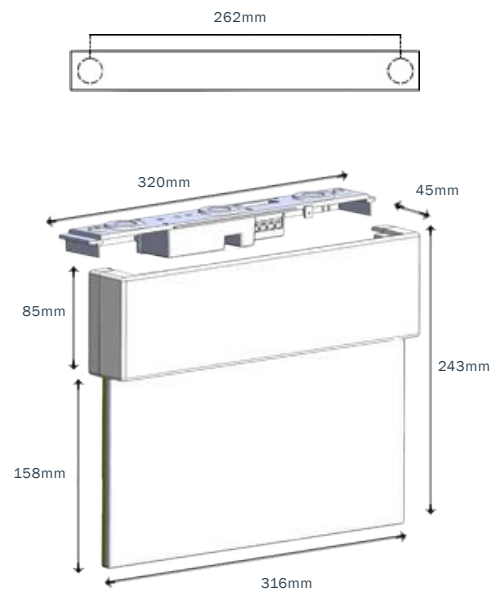

CLASS II



\*\*\*Note: Technical Specification subject to change without prior notice

# ACCESSORIES for EX-LED-M-QF



## SIDE MOUNT BRACKET

When exit signs cannot be installed above the door or on the ceiling due to visual and technical reasons, our side mount bracket is able to provide solution to do side mounting on the wall.

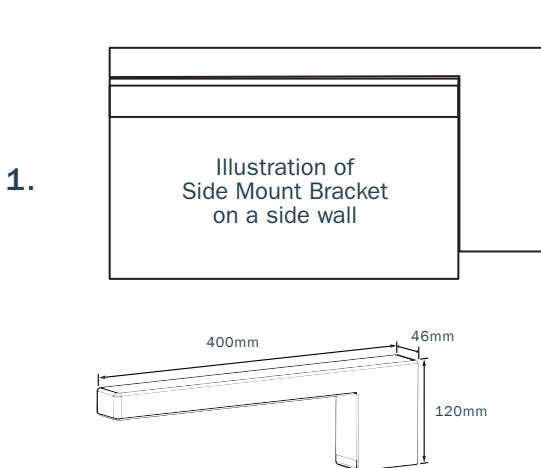

\*\*\*Note: Technical Specification subject to change without prior notice

## Ordering Guide (With Side Mount):

Legend	Single Sided	Double Sided
	EX-LED-M-QF-SIDE-S-RM	EX-LED-M-QF-SIDE-D-RM
	EX-LED-M-QF-SIDE-SR-RM	EX-LED-M-QF-SIDE-DR-RM
	EX-LED-M-QF-SIDE-SL-RM	EX-LED-M-QF-SIDE-DL-RM
	EX-LED-M-QF-SIDE-S	EX-LED-M-QF-SIDE-D
	EX-LED-M-QF-SIDE-SR	EX-LED-M-QF-SIDE-DR
	EX-LED-M-QF-SIDE-SL	EX-LED-M-QF-SIDE-DL

## Ordering Guide (With Waterproof Enclosure):

Legend	Single-Sided	Double Sided
	EX-LED-M-QF-S-RM-WP-SC-ENC	EX-LED-M-QF-D-RM-WP-SC-ENC
	EX-LED-M-QF-SR-RM-WP-SC-ENC	EX-LED-M-QF-DR-RM-WP-SC-ENC
	EX-LED-M-QF-SL-RM-WP-SC-ENC	EX-LED-M-QF-DL-RM-WP-SC-ENC
	EX-LED-M-QF-S-WP-SC-ENC	EX-LED-M-QF-D-WP-SC-ENC
	EX-LED-M-QF-SR-WP-SC-ENC	EX-LED-M-QF-DR-WP-SC-ENC
	EX-LED-M-QF-SL-WP-SC-ENC	EX-LED-M-QF-DL-WP-SC-ENC

## WEATHERPROOF ENCLOSURE

This weatherproof enclosure can assist in providing double-sided signage in wet or dusty areas and to meet local standards. The weatherproof enclosure can be mounted as followed:

