

EXB-LED-M SURFACE BOX LED

COMPACT AND CLASSIC BOX EXIT LIGHT



Ordering Guide:

Legend	Single Sided
	EXB-LED-M-S-RM
	EXB-LED-M-SR-RM
	EXB-LED-M-SL-RM
	EXB-LED-M-S
	EXB-LED-M-SR
	EXB-LED-M-SL

- Ultra bright white LEDs meeting ISO safety colour requirements.
- Exceeds SS IEC 60598-2-22 and SS 563 brightness requirements
- Extra low power consumption
- High Quality , Long Life SMD LED module
- Series connection of LEDs provides equal biasing of all LEDs ensures maximum LED life span and uniform light distribution
- Low battery voltage cut-off with latch function, to eliminate battery over discharge.
- High efficiency charger and LED converter
- Charge indicator and test switch

TECHNICAL SPECIFICATIONS

MODEL NO:	EXB-LED-M
Mode of Operation:	Maintained
Lamp:	1.2W White LED module with burning life-span > 50,000 hours
Rated Duration:	3 Hours
Mains Supply:	220-240 Volts, 50-60Hz
Power Consumption:	3W (Total standby power inclusive of LED converter)
Battery:	High Temperature Nickel Cadmium
Charger:	Regulated variable rate
Charge Monitor:	LED
Test Facility:	Micro switch
Mounting:	Suspended / Surface Ceiling / Surface Wall
Safety Features:	Low battery voltage cut off to prevent over discharge
Diffuser:	Acrylic plate (fire retardant)
Fitting Construction:	Electro galvanized steel. Epoxy powder coating for casing and gear tray
Weight:	Approx. 1.5 Kg
Dimensions:	Surface mount: 178mm (H) x 348mm (W) x 60mm (D)
Standards / Compliance:	SS IEC 60598-2-22, SS 563

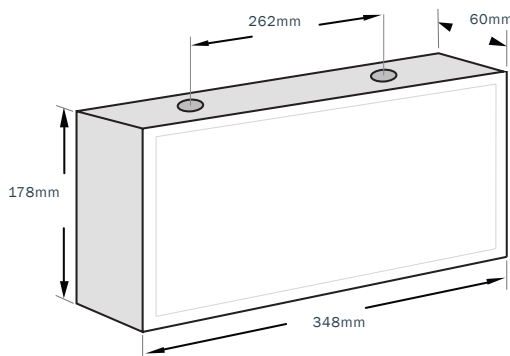

CLASS I



***Note: Technical Specification subject to change without prior notice