

# REL50NM-LED RECESS LED

**HIGH PERFORMANCE RECESS LED  
ENSURE PERFECT LIGHT DISTRIBUTION  
FOR AREAS WITH HIGH CEILING.**



## TECHNICAL SPECIFICATIONS

<b>MODEL NO:</b>	<b>REL50NM-LED</b>
Mode of Operation:	Non-Maintained
Lamp:	10W White LED
Rated Duration:	2 Hours
Mains Supply:	220-240 Volts, 50-60Hz
Power Consumption:	2.5W
Battery:	High Temperature Nickel Cadmium
Charger:	Regulated variable rate
Charge Monitor:	LED
Test Facility:	Micro switch
Safety Features:	Low battery voltage cut off to prevent over discharge
Fitting Construction:	Aluminium epoxy powder coated reflector, Steel (Charger Housing)
Weight:	Approx. 1.3 Kg
Standards / Compliance:	IEC 61347-2-13, IEC 62384, SS 563

## Ordering Guide:

### Ordering Code

Non- Maintained      REL50NM-LED-120mm

- Very Wide Spacing
- Energy savings, extra low standby power consumption
- Suitable for high ceiling recess mounting.
- Applicable to areas which require higher illuminance levels than the existing IEC standards or Singapore Standards.
- Able to provide perfect light distribution with maximum efficiency even for ceiling height which are more than 10 meters.
- Perfect as escape route lighting and anti-panic lighting.

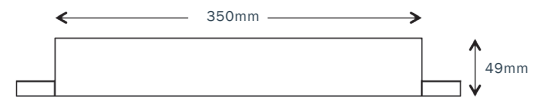
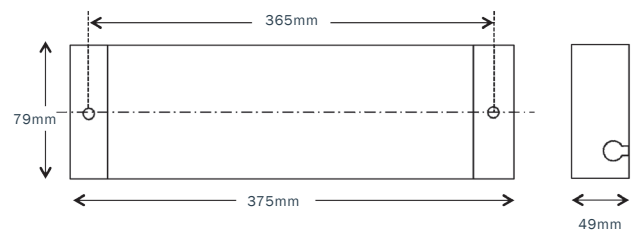

## 120mm Reflector

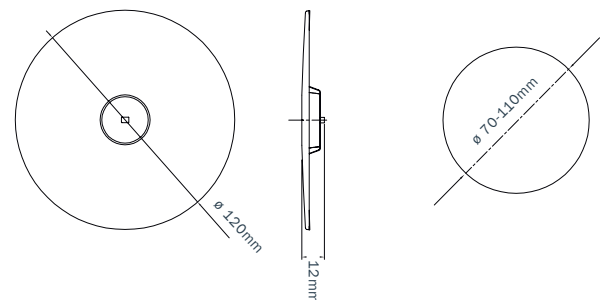

CLASS I



PSB Singapore

